

MOVEX

CV



A flexible modular filter for particles and gas

The MOVEX modular filter CV with its sturdy profile allows the possibility to satisfy the need of several functions in one product.

The filter in its basic version can be dimensioned to handle fumes from one work station. The CV filters can be connected in parallel to serve several work stations on the same system.

Maximum flexibility from a simple disposable filter to a solution with cleaning via compressed air, but also the possibility to combine particle- and gas filtration in the same unit or a gas filtration only.

The filter unit is wall mounted and the sturdy profile makes the installation easy, but also simplifies necessary service and maintenance.

The Movex range also includes fans, accessories, automatic control and local extraction for filters

FILTER
Pure advantage

MOVEX CV

Cleanable filter unit

Cleanable filtration unit with a 150 feet² filter surface in polyester. The filter cartridge is cleaned via compressed air.

Pre-filter CVM

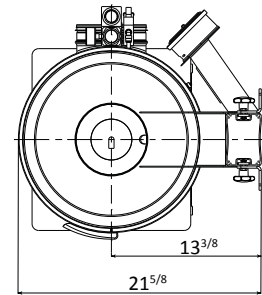
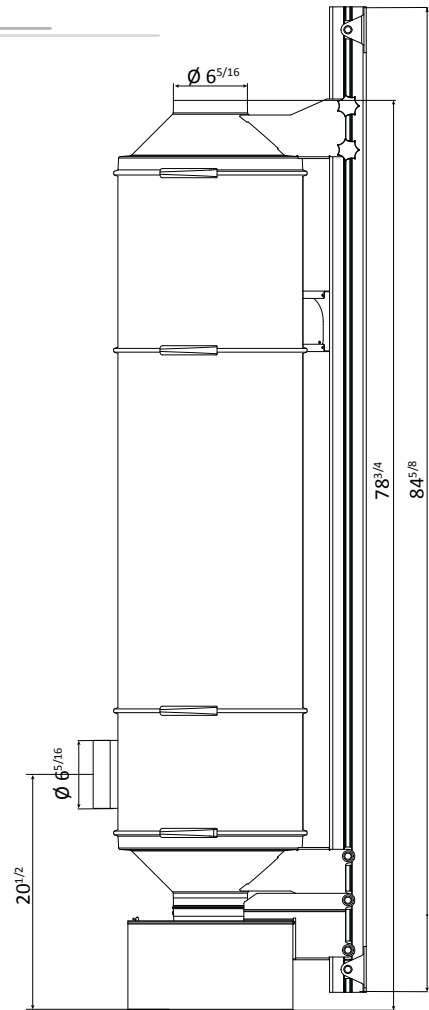
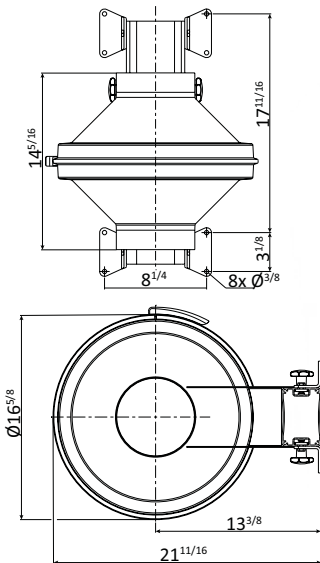

CVP

Filter with manual compressed air cleaning, with an external pre-filter including a metal mesh. For applications with large amounts of dry particles, e.g. dust- and welding smoke in mechanical industries. Delivered with a filter cartridge, profile, two connections and requisite details for compressed air cleaning. It also includes an analogue pressure gauge that shows the pressure drop over the filter cartridge. The lower duct connection is 180° adjustable.

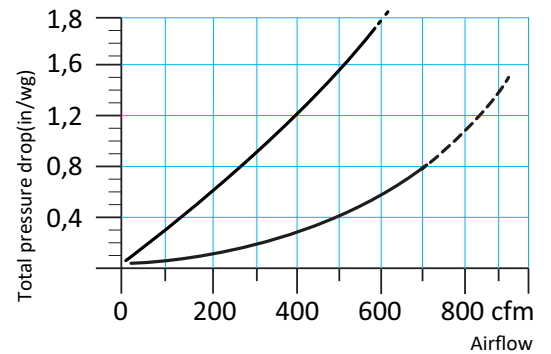

Specifications CVP

Filter casing: Powder coated steel
 Profile: Anodized aluminum
 Profile brackets: Powder coated steel
 Total weight: 116 lb
 Max. temperature processed air: 140 °F

Type of filter cartridge: CFS 149
 Material: Polyester
 Filter efficiency according to EN-60335-2-69: 99,9 %
 Dust class: M(BIA)
 Filter area: 160 ft²

CFS 149
 Polyester
 99,9 %
 M(BIA)
 160 ft²

How the CVP works

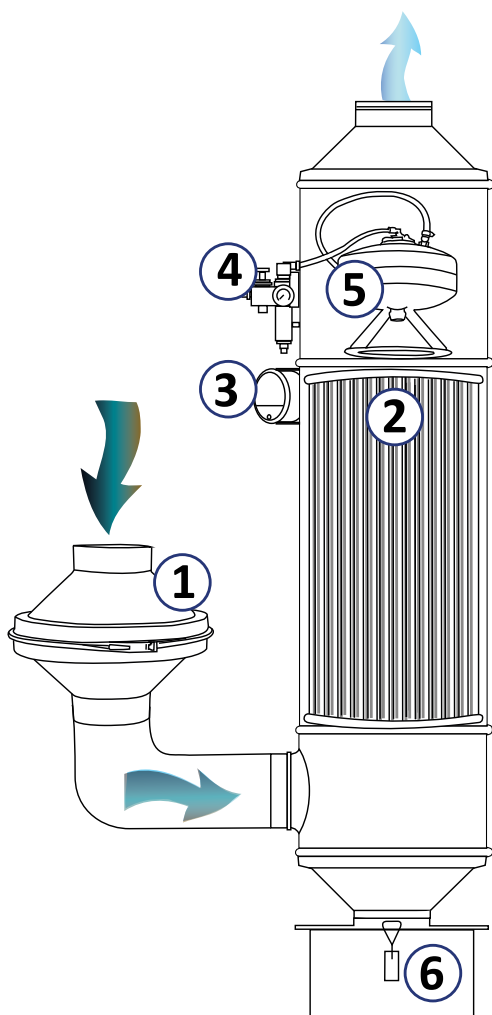

Cleanable filter type CVP

With manual compressed air cleaning the filter has a long lifetime, even when there is a high load over the filter cartridge.

1. To protect the filter cartridge from large particles, a pre-filter (CVM) is placed on the inlet channel. The pre-filter can be mounted either on the wall or directly in the duct.

A vertical position of the filter simplifies a change of the filter cartridge.

2. Filter cartridge in polyester, with BIA filter class M, 150 feet² filter area.
3. Pressure gauge that shows the pressure drop over the filter cartridge. The initial pressure over the filter cartridge is 0,4-0,8 in/wg, depending on the airflow. When the pressure drop has increased to 3-4 in/wg the filter cartridge should be cleaned via the pulse valve. The most efficient cleaning is done with the fan shut off and with 3 to 5 pulses. The filter cartridge can also be cleaned with the fan on. Indication for filter change.
4. Multi-function valve for compressed air:
 - Shut off valve and evacuation valve.
 - Pressure release function to set correct cleaning pressure 50 PSI.
 - Pressure gauge that shows the set cleaning pressure value.
 - Pulse valve to manually clean the filter cartridge.
5. Tank for compressed air with integrated pulse nozzle.
6. Below the inlet for polluted air, a bin for collection of dust is placed.

MOVEX CV

Disposable filter in steel casing

Filter unit with several options for filter cartridges (particle and gas).

The cartridge is placed inside a powder coated steel casing. The filter cartridge and steel casing is placed between two gables on an anodized aluminium profile.

For an easy filter cartridge change, the top gable is released and is lifted on the profile.

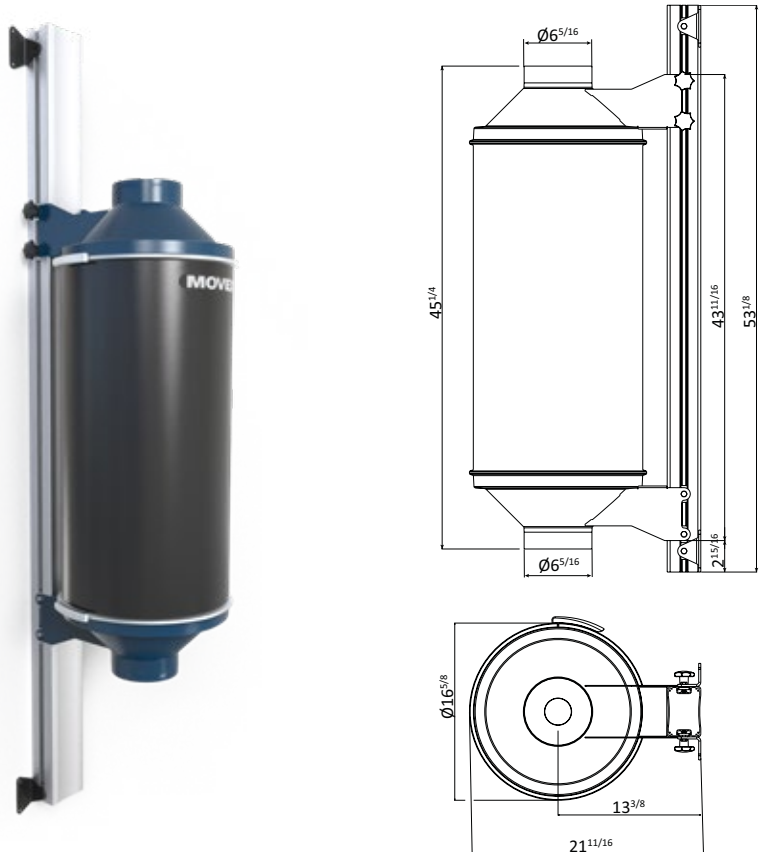

Particle filter

CVS

Filter for dry particles, e.g. dust- and welding smoke in mechanical industries. As a protection against big particles a pre-filter with a metal mesh is included inside the unit. Delivered with a filter cartridge, profile and two connections.

CVH

HEPA 13 filter with a very high level of separation. The filters are designed to create a clean zone, which is demanded when manufacturing e.g. pharmaceuticals and food. As a protection against big particles a pre-filter with a metal mesh is included inside the unit.

Delivered completely with filter cartridge, profile and two connections.

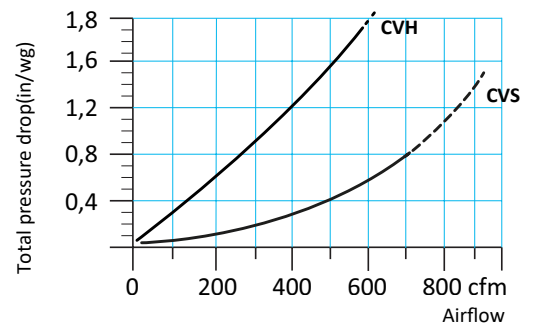

Specifications CVS

Filter casing:	Powder coated steel
Profile:	Anodized aluminum
Profile brackets:	Powder coated steel
Total weight:	60 lb
Max. temp. processed air:	140 °F

Type of filter cartridge:
Material:
Filter efficiency according
-to EN-60335-2-69:
-to DOP 0,3 µm:
Dust class:
Filter area:

CVS	CVH
CFS 149	CFH 149
Polyester	Fiberglass
99,9 %	99,95 %
M(BIA)	
160 ft ²	160 ft ²

Gas filter

CVC

The cartridge is placed inside a powder coated steel casing. Contains a standardised active carbon that is suitable for absorption of odours, gases, smoke and VOC's: e.g. toluene and methyl ethyl ketone.

To obtain the best result it's important to let the contact time between the carbon and the substance to be as long as possible. Therefore we recommend that the airflow over the filter module should not be higher than 300 cfm. For a greater airflow two or more filter modules can be placed side by side.

If the polluted air also contains particles, it's advisable to place a particle filter before the carbon filter cartridge.

Delivered with a filter cartridge, profile and two connections.

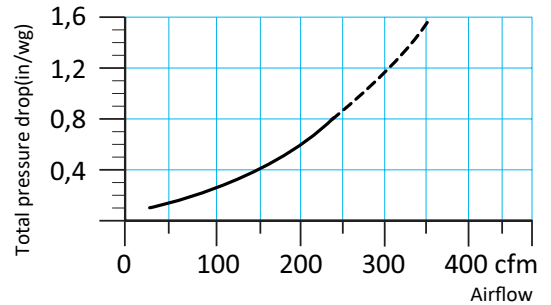

Specifications CVC

Filter casing:	Powder coated steel	Type of filter cartridge:	CFC 500
Profile:	Anodized aluminum	Weight:	35 lb
Profile brackets:	Powder coated steel	Mesh size:	3/16 ft
Total weight:	97 lb	CTC absorption (W/W):	65 %
Recommended temperature:	68 °F	Surface area (BET):	1050 m ² /gr
Max cfm:	300 cfm	Apparent density:	0,49 kg/dm ³

CVCC BiOn

The cartridge is placed inside a powder coated steel casing. Contains an impregnated active carbon that is suitable for absorption of formaldehyde and ammonia.

To obtain best result, it's important to let the contact time between the carbon and the substance to be as long as possible. Therefore we recommend that the airflow over the filter module should not be higher than 300 cfm. For a greater airflow two or more filter modules can be placed side by side. If the polluted air also contains particles, it's advisable to place a particle filter before the carbon filter cartridges.

Delivered with a filter cartridge, profile and two connections.

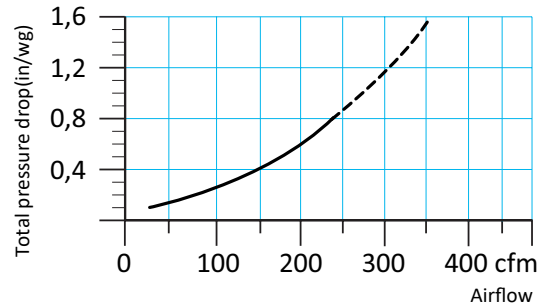

Specifications CVCC BiOn

Filter casing:	Powder coated steel	Material:	Impregnated active carbon
Profile:	Anodized aluminum	Weight:	39 lb
Profile brackets:	Powder coated steel	Mesh size:	3/16 ft
Total weight:	101 lb	CTC absorption (W/W):	45 %
Recommended temperature:	68 °F	Surface area (BET):	900 m ² /gr
Max cfm:	300 cfm	Apparent density:	0,75 kg/dm ³
Type of filter cartridge:	CFCC 500 BiOn	Impregnation KMnO ₄	11 %

Disposable filter

The filter cartridge is placed between two gables on an anodized aluminum profile.

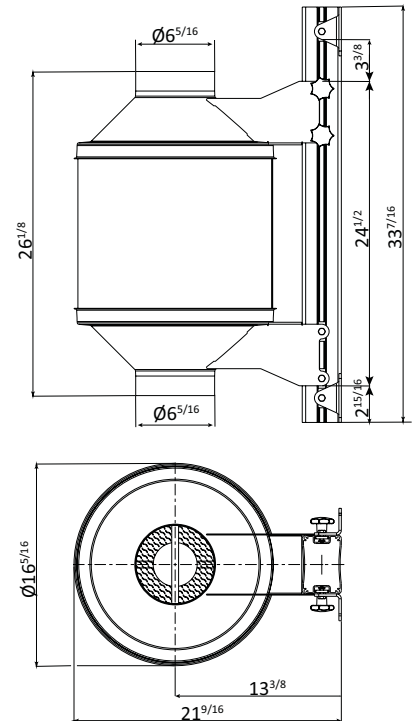

CVD

The filter cartridge has a surface area of 237 feet² in BIA class M. As a protection against big particles a pre-filter with a metal mesh is included inside the unit. The filter cartridge is placed between two gables on an anodized aluminum profile.

Delivered with a filter cartridge, profile and two connections.

For an easy filter cartridge change, the top gable is released and is lifted on the profile.

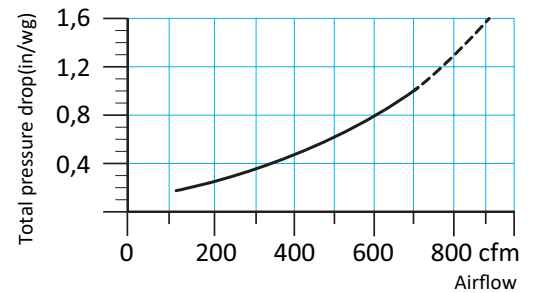

Specifications CVD

Filter casing:	Powder coated steel/paperboard	Type of filter cartridge:	CFD 220
Profile:	Anodized aluminum	Material:	Cellulose
Profile brackets:	Powder coated steel	Filter efficiency according to EN-60335-2-69:	99 %
Total weight:		Dust class:	M(BIA)
Max. temp. processed air: 140 °F		Filter area:	237 ft ²

Accessories

FBE 206

MOVEX FBE 206 is a fan with an output of 2 Hp. It provides optimal airflow and pressure for a CV filter in combination with a Movex extraction arm, making it highly suitable for e.g. welding and grinding.



FBE 206 3-phase (208-230/460 V 3~) 6.16-5.57/2.79 A

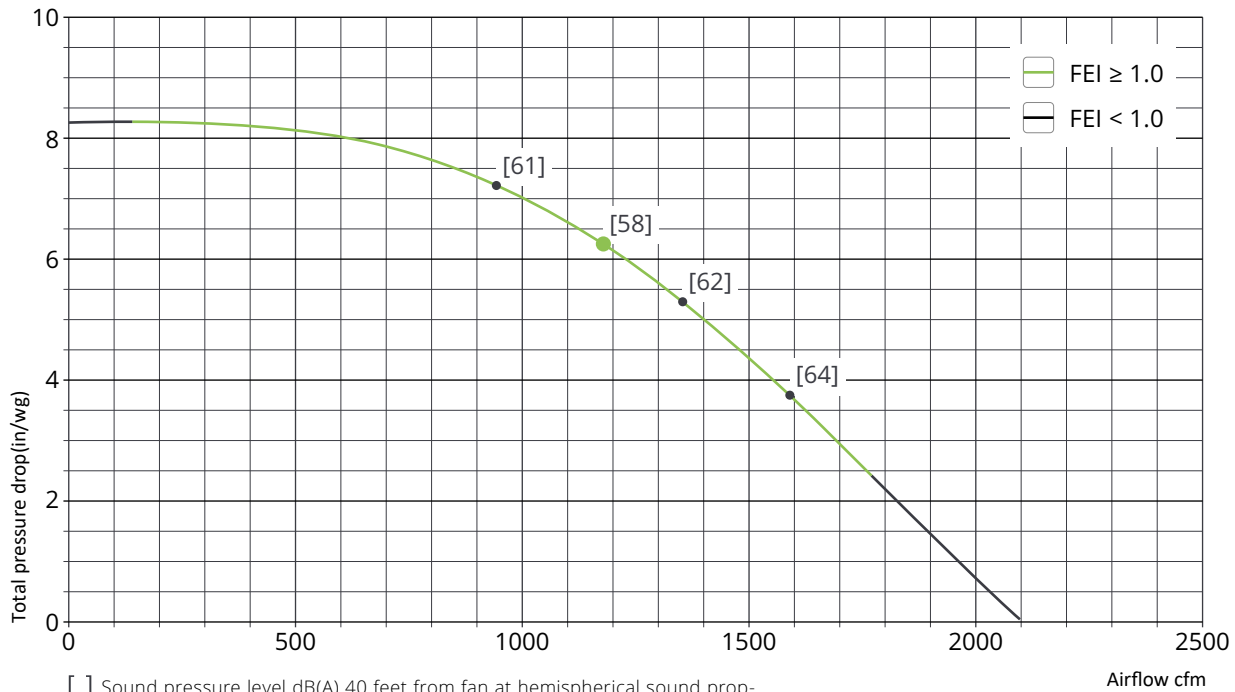

[] Sound pressure level dB(A) 40 feet from fan at hemispherical sound propagation in free field with ducted inlet and free-blowing outlet side.

● Energy-optimal operating point

CV R250-160

Reducer to FB. To be mounted on the inlet of the FB 106 for a connection to the CV filter.

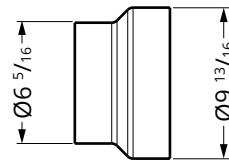
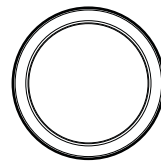

CV PR

Bracket to be mounted on wall to get the PR extractor to be lined up with the CV filter.

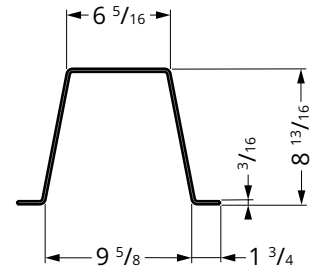
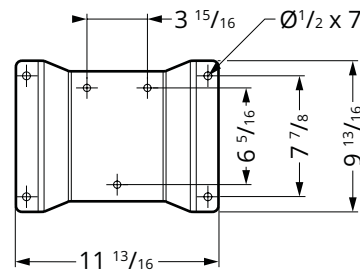

CV G

Analogue pressure gauge that shows the pressure drop over the filter cartridge. Delivered in a set with hose, connections and a bracket so it can be mounted on the aluminum profile.



Installation example

